

POWER CORD 2300 LONG OUTSIDE
(UK PLUG WITH EARTH WIRE)

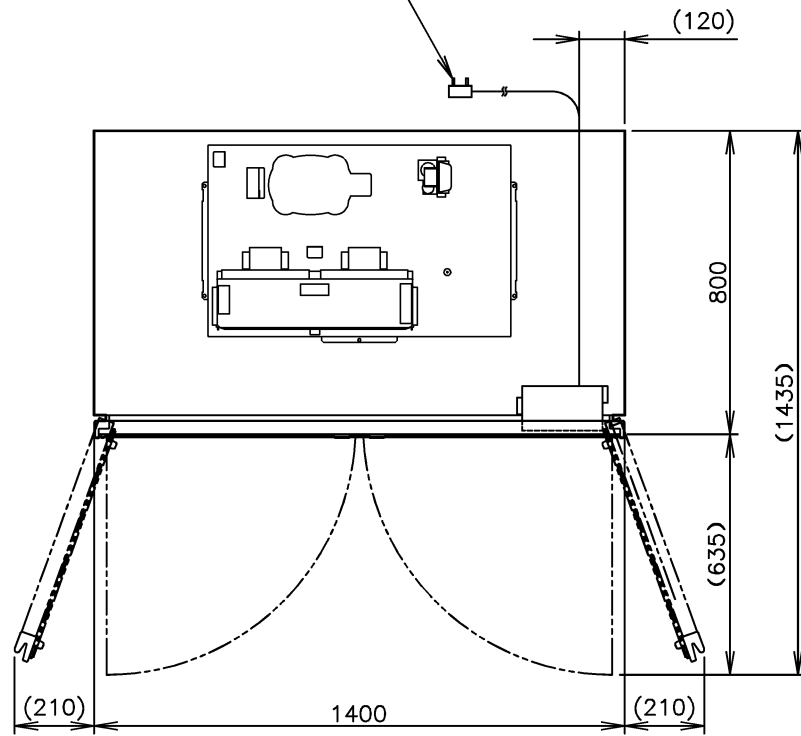

COATING SHELF(527x627) DRAIN OUTLET 18 OD (DEFROST)

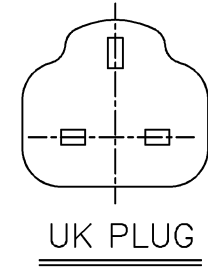
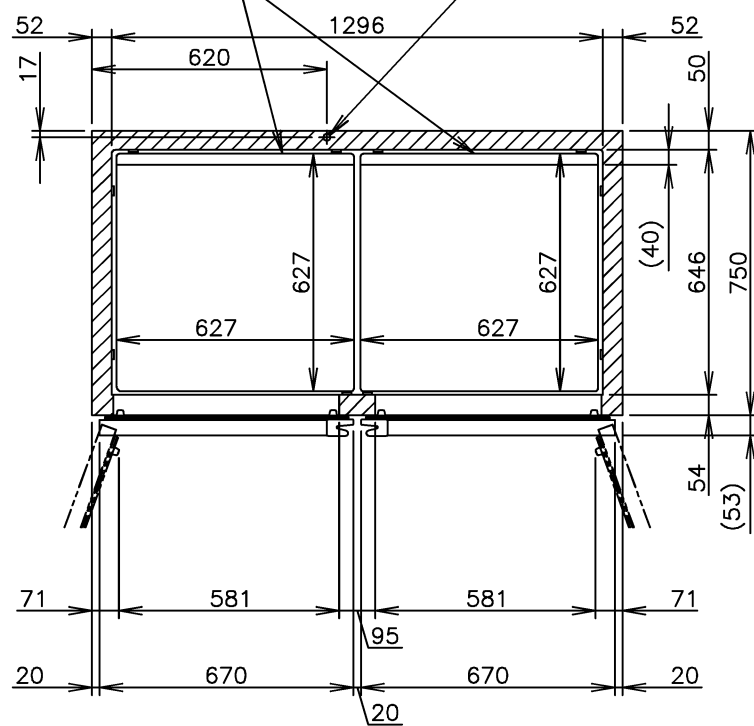

DIGITAL THERMOMETER

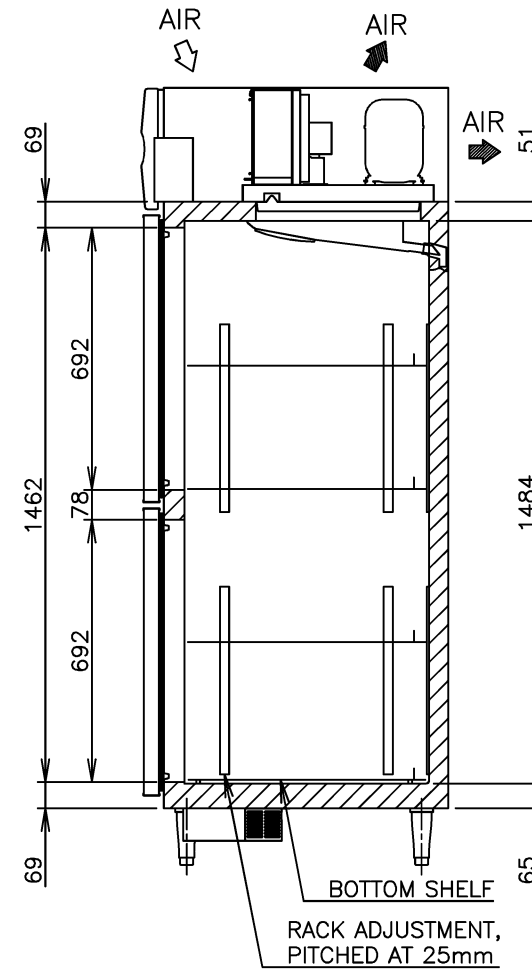
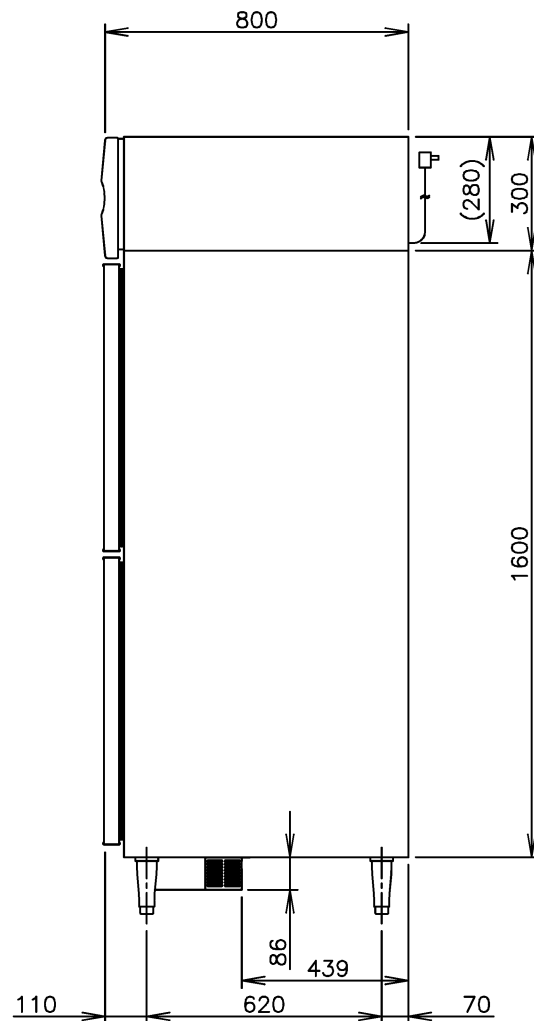
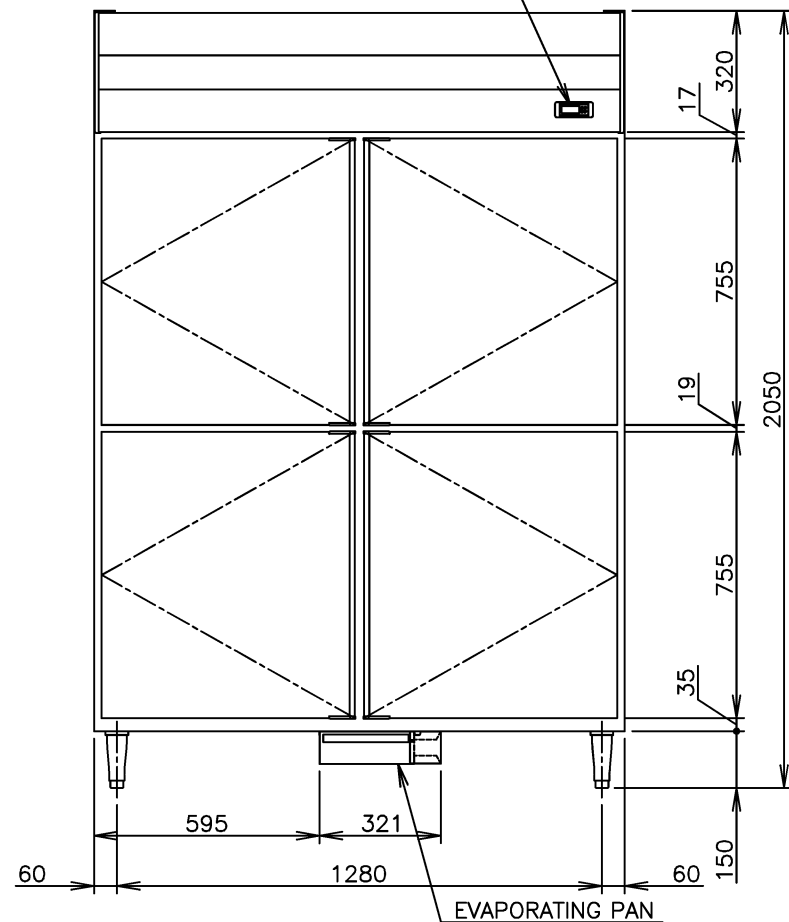

ITEM	Hoshizaki Reach-in Freezer
MODEL	HF-148MA-S
POWER SUPPLY	1 Phase 220 - 240V 50Hz Capacity: 1.26kVA (5.80A)
AMPERAGE	Rated: 5.4A Starting: 21.0A
ELECTRIC CONSUMPTION	696W (Power Factor: **%) Heater: 581W Defrost: 581W
HEAT REJECTION	1150W
POWER CORD	2.3m (UK Plug with Earth Wire)
EFFECTIVE CAPACITY	1300L
OUTSIDE DIMENSIONS	1400mm(W)× 800mm(D)× 2050(-2080)mm(H)
INSIDE DIMENSIONS	1296mm(W)× 646mm(D)× 1484mm(H)
EXTERIOR	Stainless Steel, Galvanized Steel(Top, Rear, Bottom)
INTERIOR	Stainless Steel, ABS Plastic(Door)
INSULATION	Polyurethane Foam
INSULATION FOAM BLOWING AGENT	Cyclopentane
REFRIGERATION SYSTEM	Forced Air Circulation
DEFROST SYSTEM	Heater
COMPRESSOR	Hermetic 774W
CONDENSER	Fin and Tube type, Air-cooled
EVAPORATOR	Fin and Tube type
REFRIGERANT	R404A
TEMPERATURE CONTROL	Microprocessor (Digital Temp. Indication) Adjustable from -23 to -7℃
DEFROST CONTROL	Microprocessor
ELECTRIC CIRCUIT PROTECTION	Earth Wire, Circuit Breaker
REFRIGERANT CIRCUIT PROTECTION	Motor Protector (Auto-reset)
LEG	Plastic Adjustable from 150 to 180mm
SHELF	8 pcs.
WEIGHT	168kg (Gross 202kg)
PACKAGE	Carton (Wooden Pallet) 1460mm(W)× 900mm(D)× 2075mm(H)
ACCESSORIES	Drain Hose x 1, Drain Pan x 1
OPERATING CONDITIONS	Ambient Temperature: 5 - 43℃ Voltage Range: Rated Voltage ±6%

*We reserve the right to make changes in specifications and design without prior notice.

1. Install the product properly in accordance with the instructions on location, water supply/ drain connections and electrical connections stated in the instruction and installation manuals provided.
Allow 10mm extra space at the installation site to meet any installation requirements (additional spacing is also required for proper air flow and pipe connections).
2. The heat rejection is based on the reached pulldown temperature at ambient temperature of 35℃.
3. Product Code: R569-D100 (HS)

HOSHIZAKI REACH-IN FREEZER HF-148MA-S

APPROVED KAWAKAMI	CHECKED WANG	DESIGNED LIANG	DRAWN KAWAKAMI	SCALE 1/20	TRIGONOMETRY
*	*	△	*****	DATE 2018.10.17	DRAWING NO. D23744
APPROVED	DESIGNED	SYMBOL	DATE		SYMBOL △