

ITEM	Hoshizaki Reach-in Refrigerator
MODEL	HR-188MA-S
POWER SUPPLY	1 Phase 220 - 240V 50Hz Capacity: 0.86kVA (3.90A)
AMPERAGE	Rated: 3.6A Starting: 13.1A
ELECTRIC CONSUMPTION	413W Heater: 433W Defrost: 433W
HEAT REJECTION	*W
POWER CORD	2.3m (UK Plug with Earth Wire)
EFFECTIVE CAPACITY	1632L
OUTSIDE DIMENSIONS	1800mm(W) x 800mm(D) x 2050(-2080)mm(H)
INSIDE DIMENSIONS	1696mm(W) x 646mm(D) x 1484mm(H)
EXTERIOR	Stainless Steel, Galvanized Steel(Top, Rear, Bottom)
INTERIOR	Stainless Steel, ABS Plastic(Door)
INSULATION	Polyurethane Foam
INSULATION FOAM BLOWING AGENT	Cyclopentane
REFRIGERATION SYSTEM	Forced Air Circulation
DEFROST SYSTEM	Heater
COMPRESSOR	Hermetic
CONDENSER	Fin and Tube type, Air-cooled
EVAPORATOR	Fin and Tube type
REFRIGERANT	R134a
TEMPERATURE CONTROL	Microprocessor (Digital Temp. Indication) Adjustable from -6 to 12°C
DEFROST CONTROL	Microprocessor
ELECTRIC CIRCUIT PROTECTION	Earth Wire, Circuit Breaker
REFRIGERANT CIRCUIT PROTECTION	Motor Protector (Auto-reset)
LEG	Plastic Adjustable from 150 to 180mm
SHELF	12 pcs.
WEIGHT	184kg (Gross 226kg)
PACKAGE	Carton (Wooden Pallet) 1860mm(W) x 900mm(D) x 2075mm(H)
ACCESSORIES	Drain Hose x 1, Drain Pan x 1
OPERATING CONDITIONS	Ambient Temperature: 5 - 43°C Voltage Range: Rated Voltage ±6%

\*We reserve the right to make changes in specifications and design without prior notice.

1. Install the product properly in accordance with the instructions on location, water supply/drain connections and electrical connections stated in the instruction and installation manuals provided.  
Allow 10mm extra space at the installation site to meet any installation requirements (additional spacing is also required for proper air flow and pipe connections).
2. The heat rejection is based on the reached pull-down temperature at ambient temperature of 35°C.
3. Product Code: R593-C100 (HS)

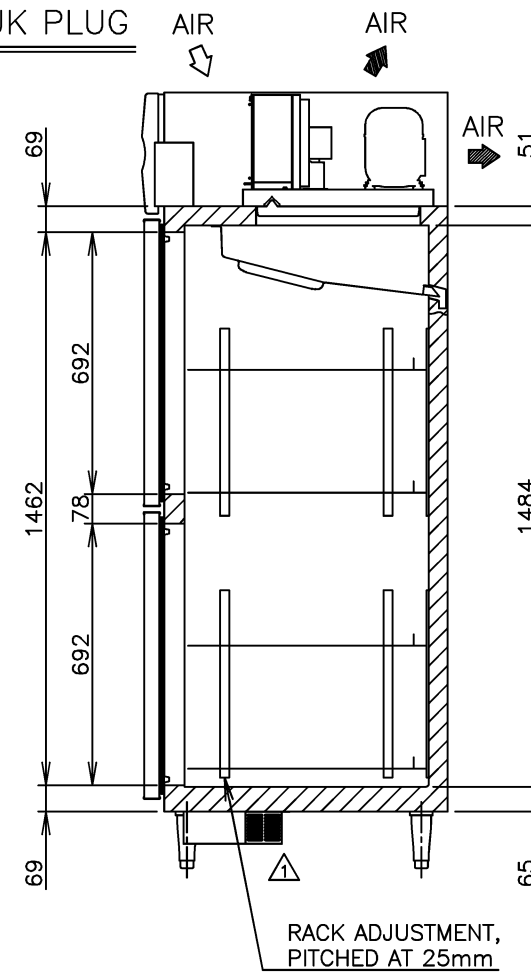
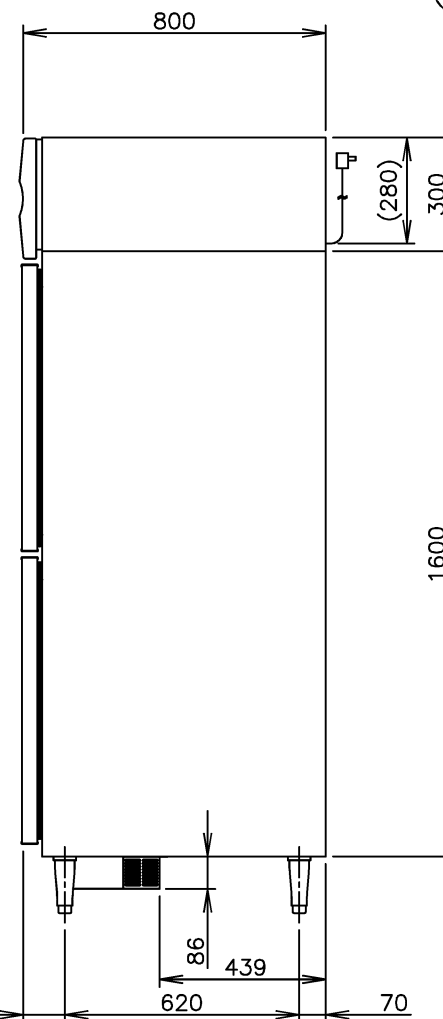
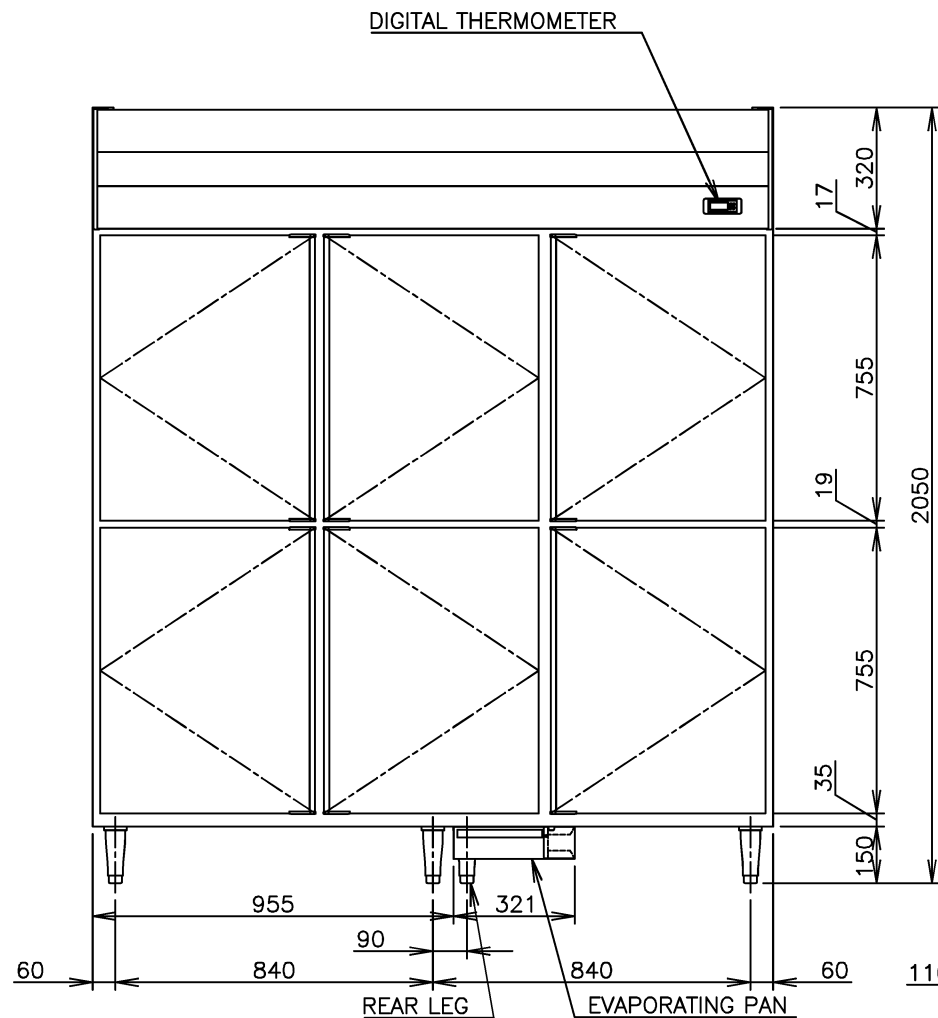

# HOSHIZAKI REACH-IN REFRIGERATOR HR-188MA-S

APPROVED KAWAKAMI	CHECKED WANG	DESIGNED LIANG	DRAWN ZHOU	SCALE 1/20	TRIGONOMETRY
KAWAKAMI APPROVED	SHAN DESIGNED	2019.07.26 DATE	2019.06.06 DATE	DRAWING NO. D25224	SYMBOL 1